

New Ledger Attachment Requirements Adopted

Bolting schedule and lateral attachment brackets are part of the 2007 IRC Supplement

by Cheri B. Hainer

Ledger-board attachment is a key element in deck failures. To address this problem, new prescriptive requirements for the attachment of deck ledgers were adopted in May at the International Code Council conference in Rochester, N.Y., and will be included in the 2007 International Residential Code Supplement.

An event underlining the need for this code change occurred in Virginia Beach, Va., on October 28, 2005. At a wedding reception, a third-floor deck holding 40 guests collapsed (see photo, right), and 28 people required medical treatment. The residence was located on a beach along the Atlantic Ocean; investigators found that the joist hangers and the nails used to attach the joists to the ledger board had rusted through. Also, because the ledger board wasn't bolted onto the house, it separated from the house as the deck collapsed.

The following month — though not in response to the Virginia Beach accident — the Virginia Uniform Statewide Building Code adopted provisions similar to those just adopted by the ICC.

Although the code-development community tries to be proactive, most



current codes are reactions to events. For example, new wind-resistant construction requirements were adopted in response to construction failures during Hurricanes Andrew, Isabelle, Katrina, and Ernesto. More restrictive nightclub provisions were prompted by a fire in Rhode Island that killed 100 people. And recent deck collapses (like the one mentioned above, and others in Atlanta; Kalamazoo, Mich.; St. Louis; Chicago; and on the New Jersey shore) led to the new ledger-attachment code provisions.

Once a building problem has been identified, substantial research is conducted by universities, testing labs, the ICC's own facility, manufacturers, and

the like to determine the cause of the problem and then ensure that it is sufficiently addressed.

Most of the aforementioned decks were based on approved engineering designs. The failures occurred where the deck was attached to the primary structure; in many cases, the deck ledger had been attached to the house with nails rather than bolts, a method that was code compliant in many areas at the time the decks were built. Rust and decay of the nails also apparently accelerated the separation of the ledger board from the structure, which eventually caused the decks to collapse.

Researchers at Virginia Tech University and Washington State University

Codes Finally Clarify Ledger Attachment

TABLE R502.2.2.1 Fastener Spacing for a Southern Pine or Hem-Fir Deck Ledger and a 2-Inch Nominal Solid-Sawn Spruce-Pine-Fir Band Joist Deck Live Load + 40 psf, Deck Dead Load = 10 psf ^{3,6,7}							
Joist Span (ft)	6' and less	6'-1" to 8'	8'-1" to 10'	10'-1" to 12'	12'-1" to 14'	14'-1" to 16'	16'-1" to 18'
Connection Details	On-Center Spacing of Fasteners ^{4,5}						
1/2" diameter lag screw with 1 5/32" maximum sheathing ¹	30	23	18	15	13	11	10
1/2" diameter bolt with 1 5/32" maximum sheathing	36	36	34	29	24	21	19
1/2" diameter bolt with 1 5/32" maximum sheathing and 1/2" stacked washers ^{2,8}	36	36	29	24	21	18	16
¹ The tip of the lag screw shall fully extend beyond the inside face of the band joist. ² The maximum gap between the face of the ledger board and face of the wall sheathing shall be 1/2". ³ Ledgers shall be flashed to prevent water from contacting the house band joist. ⁴ Lag screws and bolts shall be staggered per R502.2.2.1.1. ⁵ Deck ledger shall be minimum 2x8 pressure-preservative-treated No. 2 grade lumber or other approved materials as established by standard engineering practice. ⁶ When solid-sawn pressure-preservative-treated deck ledgers are attached to engineered wood products (structural composite lumber rimboard or laminated veneer lumber), the ledger attachment shall be designed in accordance with accepted engineering practices. ⁷ A minimum 1x9 1/2 Douglas Fir laminated veneer rimboard shall be permitted in lieu of the 2-inch nominal band joist. ⁸ Wood structural panel sheathing, gypsum board sheathing, or foam sheathing not exceeding one inch in thickness shall be permitted. The maximum distance between the face of the ledger board and the band of the joist shall be one inch.							

tested simulated deck ledger-to-house band joist connections. The testing included a practical range of pressure-preservative-treated (PPT) deck-ledger lumber (incised hem-fir and southern pine) attached to a simulated spruce-pine-fir band joist by 1/2-inch lag screws or bolts with washers. The deck ledger was separated from the band joist by a piece of 1 5/32-inch wall sheathing. In a separate test for bolts only, a 1/2-inch stack of washers was inserted between the ledger and the sheathing to produce a drainage plane.

The specimens were tested to failure (Figure 1); average test results were divided by a factor of 3.0 — intended to provide an adequate in-service safety

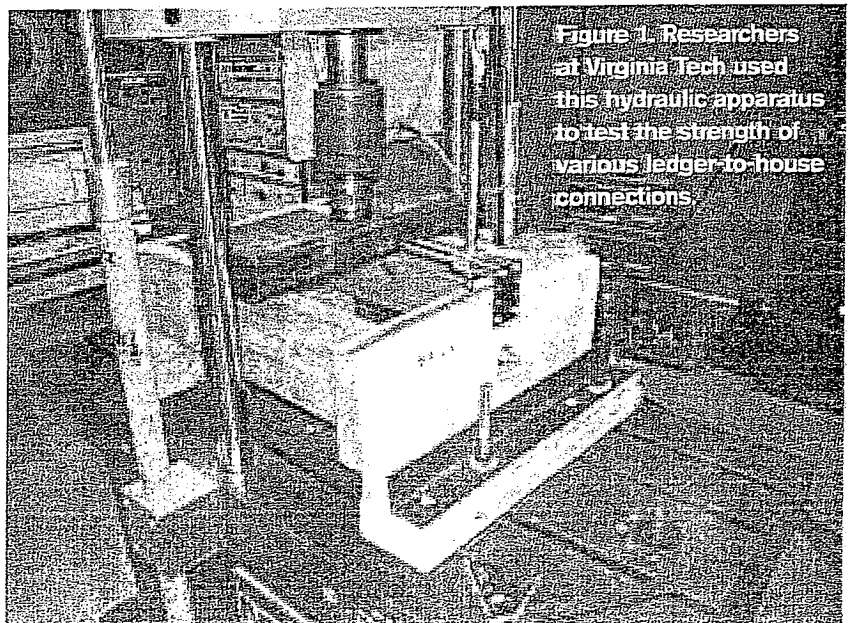

Figure 1. Researchers at Virginia Tech used this hydraulic apparatus to test the strength of various ledger-to-house connections.

New Ledger Attachment Requirements Adopted

factor — and further divided by 1.6 to convert from a “test duration” to a “normal duration” of 10 years, which is recognized by the International Building Code as the proper duration for occupancy live load. The findings, nationally published in “Wood Bits: Residential Deck Ledger Design” in *Building Safety Journal* (December 2005) and “Load-Tested Deck Ledger Connections” in *The Journal of Light Construction* (November 2005), were the basis for the recently approved code change.

Below is the resulting code provision approved at the ICC Final Action Hearings in Rochester in May:

R502.2.2.1 Deck ledger connection to band joist. For decks supporting a total design load of 50 psf (40 psf live load and 10 psf dead load), the connection between a deck ledger of pressure-preservative treated Southern Pine, incised pressure-preservative treated Hem-Fir, or approved decay-resistant species, and a 2-inch nominal band joist bearing on a sill plate or wall plate shall be constructed with 1/2-inch lag screws or bolts with washers per Table R502.2.2.1. Lag screws, bolts, and washers shall be hot-dipped galvanized or stainless steel.

The proposed on-center spacing is the more conservative number that was found to be adequate in testing by the two universities for the two cases of deck-ledger lumber studied.

Because of limited information on the performance of composite-type rimboards and the possibility of new products entering the market of a lower quality than those tested, engineered rimboards are not included in the scope of the fastener spacing table (see page 2). Instead, as referenced in footnote 6 of Table R502.2.2.1, the contractor or building official needs to refer to the manufacturer of the rimboard product.

Also, the researchers tested specimens with a 1x9 1/2-inch LVL rimboard, so footnote 7 allows LVL to be

Deck Attachment for Lateral Loads

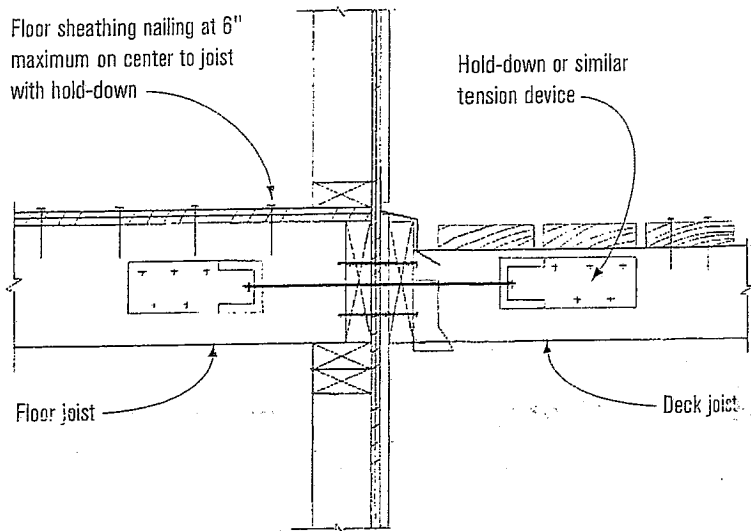

Figure 2. An illustration for the newly adopted code changes shows the lateral attachment requirements.

substituted for the 2x8 band joist. Most important, footnote 8 allows the use of other types of sheathing, up to 1 inch in thickness, as long as the distance between the face of the band joist and the face of ledger is not greater than 1 inch. This allows the ledger table to be used for decks attached to houses sheathed with those alternative materials.

The following two additional sections have been included in the provision to allow the installer flexibility in locating the lag screw or bolt so that it does not interfere with installation of the structural connector; to clarify requirements for an engineered design; and to prohibit deck attachments to masonry veneer:

R502.2.2.1.1 Placement of lag screws or bolts in deck ledgers. The lag screws or bolts shall be placed two inches in from the bottom or top of the deck ledgers and between two and five inches in from the ends. The lag screws or bolts shall be staggered from the top to the bottom along the horizontal run of the deck ledger.

R502.2.2.2 Alternate deck ledger connections. Deck ledger connections not conforming to Table R502.2.2.1 shall be designed in accordance with accepted engineering practice. Girders supporting deck joists shall not be supported on deck ledgers or band joists. Deck ledgers shall not be supported on stone or masonry veneer.

Finally, to address concerns in high-wind zones and ensure that the rimboard is adequately anchored into the floor system (Figure 2), Section R502.2.2.3 requires positive anchorage of the deck joists to the floor framing (this provision is similar to a FEMA construction requirement):

R502.2.2.3 Deck lateral load connection. The lateral load connection required by Section R502.2.2 shall be permitted to be in accordance with Figure R502.2.2. Hold-down tension devices shall be provided in not less than two locations per deck, and each device shall have an allowable stress design capacity of not less than 1500 lb. ❖

Cheri B. Hainer is a code-enforcement official in Fairfax County, Va.